



Krell Industries, Inc.
20 Higgins Drive
Milford, CT 06460, USA

TECHNICAL INFORMATION FOR THE KSA-80, KMA-160,

KSA-200, KMA-400 AMPLIFIERS, NOVEMBER 1, 1988

NOTES ON TRANSFORMERS TYPES IN KRELL AMPLIFIERS

There have been transformers made by two different manufacturers used in the new Programmable series amplifiers. During the time period of March through September 1988 transformers from Avel-Lindberg were used. In September 1988 we began using transformers made by Holden & Fisher. There are differences in the wire color codes and some of the secondary voltages. A separate sheet is included here that details these technical differences. Please refer to the visual descriptions below to determine which type transformer is in your unit before proceeding with any work.

AVEL-LINDBERG: The transformer can is painted a matte black finish. The upper corners are rounded.

HOLDEN & FISHER: The transformer can is painted a glossy black finish. The upper corners have almost no radius, and are virtually squared-off.

11.1.1988

KRELL TRANSFORMER WIRE COLOR CODE GUIDE, 11.1.1988

KSA-80/KMA-160

<u>Transformer Type</u>		<u>Avel-Lindberg</u>	<u>Holden & Fisher</u>
a. Primary:	0	Black	Black
	100	Brown	Brown
<u>18 gauge wires</u>	120	Red	Red
	0	Black/White	Blue
	100	Brown/White	Grey
	120	Red/White	Violet
b. Secondary:	0	Black	Black
	37	Brown	Grey
<u>14 gauge wires</u>	45	Red	Blue
	0	Black/White	Violet
	37	Brown/White	Green
	45	Red/White	Pink
<u>22 gauge wires</u>	11	Orange	Orange
	0	Orange/Black	Orange/Black
	11	Orange	Orange
	70	Yellow	Yellow
	0	Grey	Grey
	70	Yellow	Yellow
c. Screen		Green/Yellow	Green/Yellow

*Note: Voltages are accurate for the Holden & Fisher transformers only.

KRELL TRANSFORMER WIRE COLOR CODE GUIDE, 11.1.1988

KSA-200/KMA-400

<u>Transformer Type</u>		<u>Avel-Lindberg</u>	<u>Holden & Fisher</u>
a. Primary:	0	Black	Black
	100	Brown	Brown
<u>18 gauge wires</u>	120	Red	Red
	0	Black/White	Blue
	100	Brown/White	Grey
	120	Red/White	Violet
b. Secondary:	0	Black	Black
	55	Brown	Grey
<u>14 gauge wires</u>	70	Red	Blue
	0	Black/White	Violet
	55	Brown/White	Green
	70	Red/White	Pink
<u>22 gauge wires</u>	11	Orange	Orange
	0	Orange/Black	Orange/Black
	11	Orange	Orange
	70	Yellow	Yellow
	0	Grey	Grey
	70	Yellow	Yellow
c. Screen		Green/Yellow	Green/Yellow

*Note: Voltages are accurate for the Holden & Fisher transformers only.

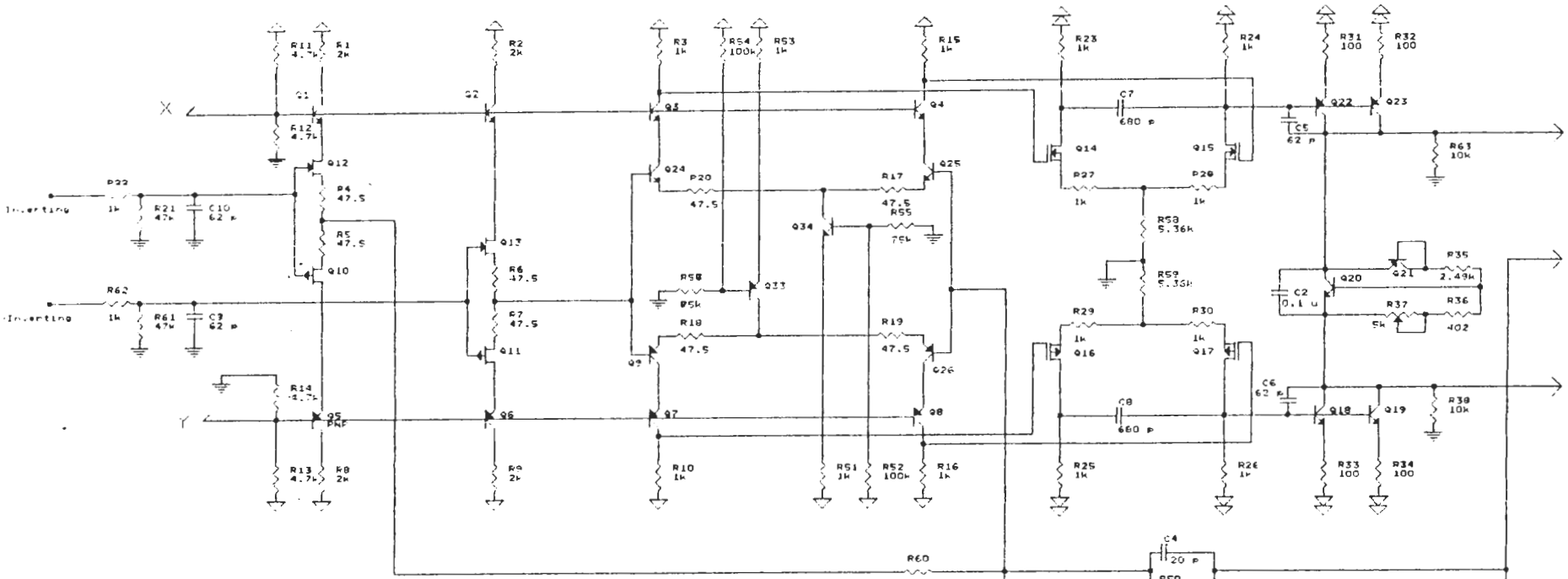

TO
Driver
Board

Power Supply

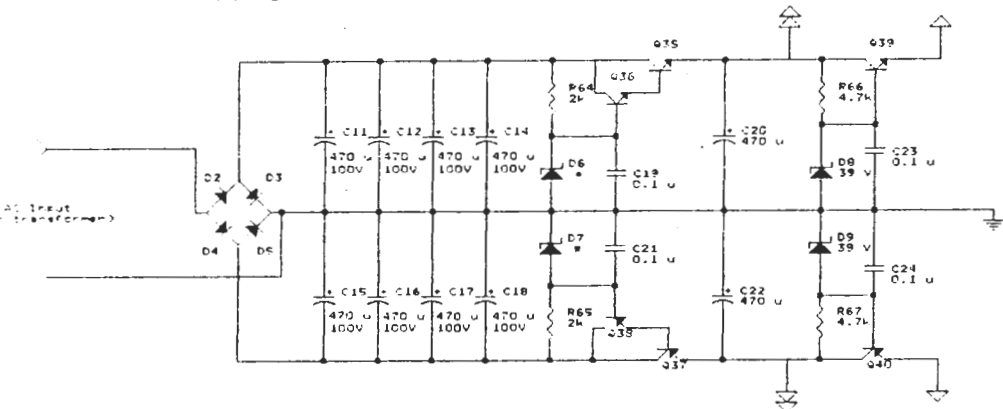

- * Zener Diode Values
- *SA90 7.5 V
 - *MR160 7.5 V
 - *SA200 8.2 V
 - *MA300 6.2 V
 - *SA1 XFRMR 82 V
 - Holden XFRMR 87 V

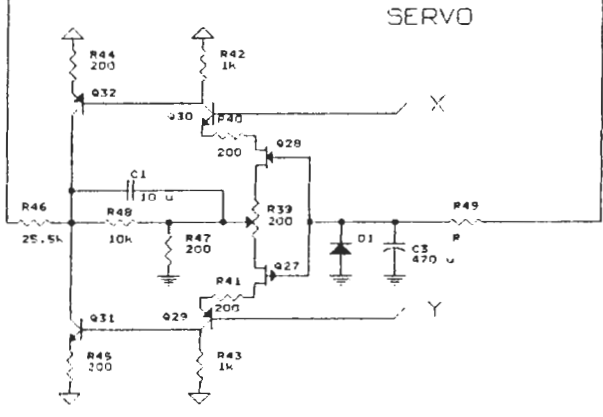

POWER SUPPLY AND BIAS SPECIFICATIONS FOR

KSA-80, KSA-200, KMA-160, KMA-400

1. BIAS

Measured across emitter resistors on the output heatsinks

ALL UNITS: 325 mv +/- 5 mv

2. HIGH POWER UNREGULATED DC POWER SUPPLY VOLTAGES

Measured on the Buss Bars in the Main Power Supply

KSA-80	+/- 53 volts
KMA-160	+/- 63 volts
KSA-200	+/- 77 volts
KMA-400	+/- 90 volts

3. HIGH VOLTAGE AC INTO AUDIO BOARD

Measured at 2-pin AMP connector located at front of Audio Board.

a. AVEL-LINDBERG TRANSFORMERS

KSA-80/KMA-160	120 volts
KSA-200/KMA-400	125 volts

b. HOLDEN & FISHER TRANSFORMERS

All units	145 volts
-----------	-----------

4. DC SUPPLY VOLTAGES ON THE AUDIO BOARD

KSA-80	+/- 75 volts	+/- 39 volts
KMA-160	+/- 75 volts	+/- 39 volts
KSA-200	+/- 82 volts	+/- 39 volts
KMA-400	+/- 82 volts	+/- 39 volts with Avel-Lindberg units
	+/- 87 volts	+/- 39 volts with Holden & Fisher units*

*Note: All units shipped after December 1, 1988 will be +/- 87 volts, +/- 39 volts and built only with Holden & Fisher transformers.

Also: All units shipped after November 11, 1988 will have the protection circuitry set for driving loads down to .5 ohms.

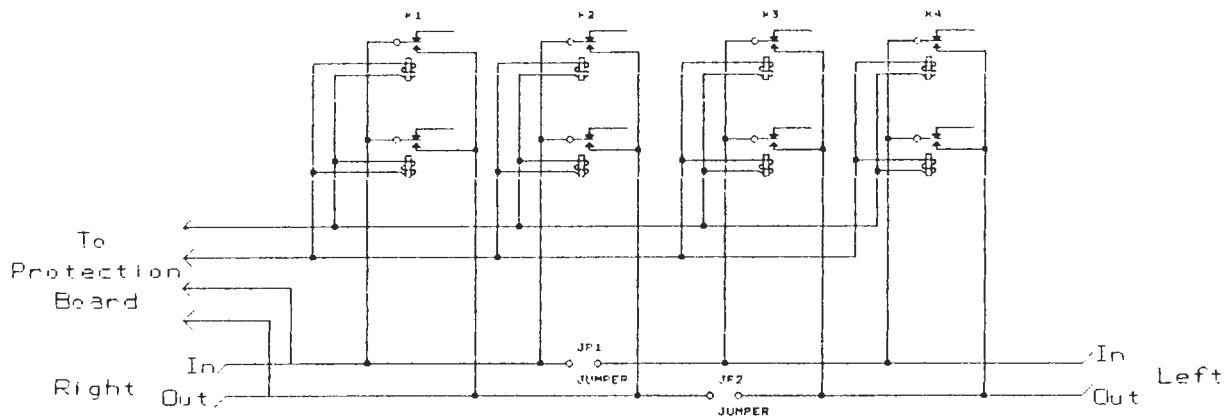

Relay Board

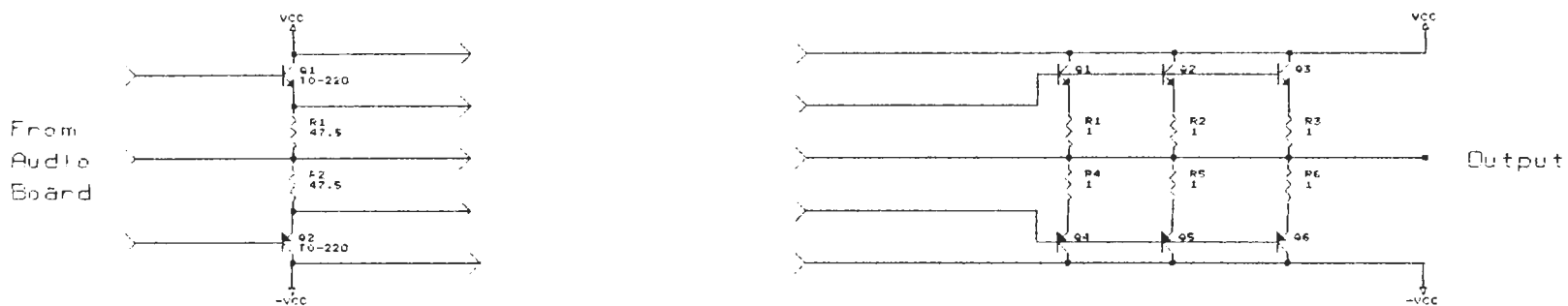

Driver Board

T-Bar

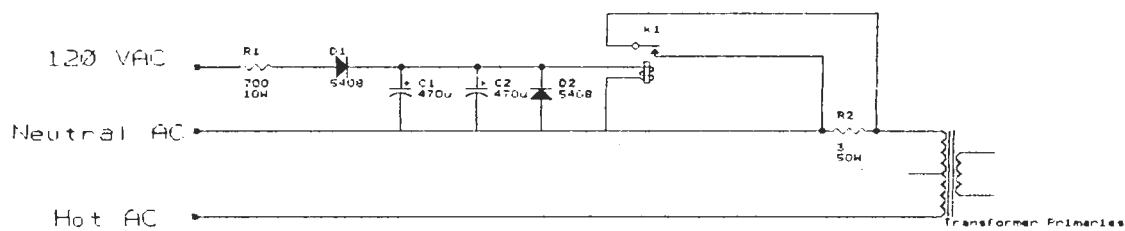

Slow-Start

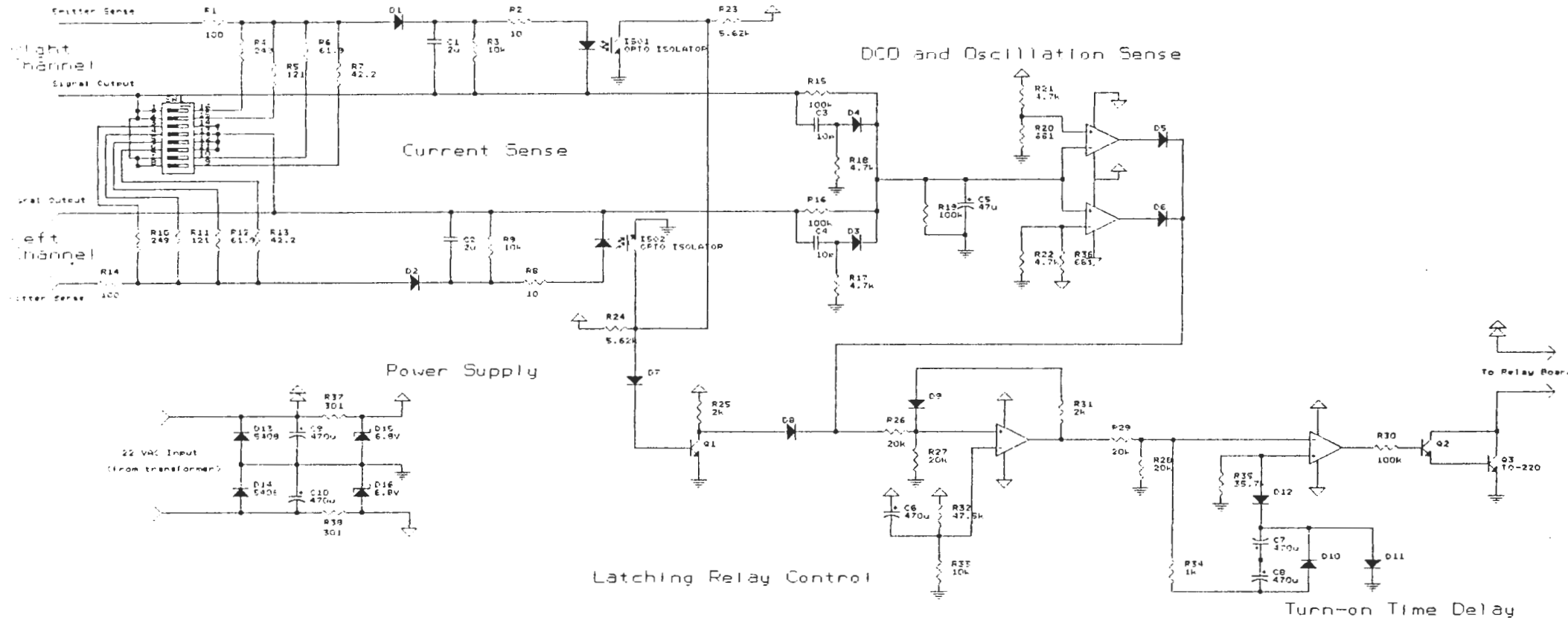

KRELL Industries 20 Higgins Drive Milford, CT 06460	
Title	Protection Board
Size/Document Number	
c	